



12th ICSGE

10-12 Dec. 2007

Cairo - Egypt

Ain Shams University

Faculty of Engineering

Department of Structural Engineering

Twelfth International Colloquium on Structural and Geotechnical Engineering

BEHAVIOR OF LARGE DIAMETER MONOPILES UNDER CYCLIC HORIZONTAL LOADING

M. ACHMUS

Head of Institute of Soil Mechanics, Foundation Engineering and Waterpower Eng.

Leibniz University of Hannover, Appelstr. 9A, Hannover, Germany

E-mail: achmus@igbe.uni-hannover.de

K. ABDEL-RAHMAN

Institute of Soil Mechanics, Foundation Engineering and Waterpower Eng.

Leibniz University of Hannover, Appelstr. 9A, Hannover, Germany

E-mail: khalid@igbe.uni-hannover.de

Y.-S. KUO

Institute of Soil Mechanics, Foundation Engineering and Waterpower Eng.

Leibniz University of Hannover, Appelstr. 9A, Hannover, Germany

E-mail: kuo@igbe.uni-hannover.de

ABSTRACT

In order to achieve economic use of offshore wind energy, the foundation structures should be designed with sufficient stiffness under minimum costs. One foundation concept which was recently often realized in this field is the monopile concept. Here the foundation consists of one steel pile with a large diameter of up to or even more than 5 m. This paper aims to investigate the behavior of such a monopile under cyclic loading taking the interaction between the pile and the subsoil into account. A three-dimensional numerical model using the finite element method was developed. In this model the non-linear material behavior of the subsoil is described using an elasto-plastic constitutive model. A special numerical scheme was developed to account for the effect of cyclic loading. With this scheme, the increase of pile displacement with the number of loading cycles can be quantified.

KEYWORDS

Offshore wind energy plants, monopile, cyclic loading, finite element method, displacement accumulation, stiffness degradation.

1 INTRODUCTION

The offshore wind farms planned in the German part of North and Baltic Sea will be constructed in water depths varying from approximately 15 to 40 m. By means of suitable foundation constructions, the large horizontal forces and bending moments

resulting from wind and wave loadings must be economically and safely transferred to the sea soil. For this, monopile foundations can be used. In principle the monopile is an extension of the main tower into the soil under the sea bed (Fig. 1). Monopiles with diameters of up to 5 m have been constructed recently in water depths of up to 15 m. The application is expected to be possible for water depths up to about 25 to 30 m. The monopile diameters in such depths will vary between 6 and 8 m.

Since wind energy plants are relatively sensitive to deformations, in particular tilting, it is very important to estimate these as exactly as possible. For the mentioned large-diameters piles, till now no approved design procedure is available. The p-y curve method given in the API regulations (API 2000), which is usually used for the design of offshore piles, was developed for piles with maximum diameters of about 2 m. In this paper, the results of numerical investigations of the load-deformation behavior of large diameter monopiles under cyclic loading are presented.

2 NUMERICAL MODELLING OF MONOPILE BEHAVIOR UNDER STATIC MONOTONIC LOADING

For the investigation of the load-deformation behavior of monopiles of large diameters, three-dimensional finite element calculations were performed. For that, an idealized homogeneous soil typical for North Sea conditions consisting of medium dense or dense sand was considered. A monopile diameter of $D = 7.5$ m and a wall thickness of 9 cm was assumed in the following calculations.

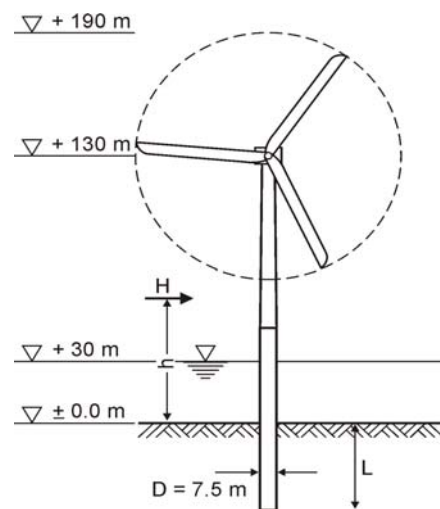

Fig.1: Example of a monopile foundation.

The finite element model is shown in Figure 2. The behavior of the pile under a vertical load of 10 MN representing the structure's weight and a variable horizontal load H acting in a certain height h above the sea level was investigated. By variation of the load application height h combinations of horizontal force H and bending moment $M = H \times h$ were realized.

Due to the symmetric loading condition only a half-cylinder representing the subsoil and the monopile could be considered. The discretized model area had a diameter of 90 m, which is twelve times the pile diameter. The bottom boundary of the model was

taken 15 m below the base of the monopile. With these model dimensions the calculated behavior of the pile is not influenced by the boundaries.

The computations were done with the program system ABAQUS (Abaqus 2006). In order to carry out a lot of calculations for varying boundary and loading conditions, an advanced computer system with parallel processor technology was used to minimize the computation time.

Of crucial importance for the quality of the numerical computation results of soil structure interaction problems is the modelling of the material behavior of the soil. The elasto-plastic material law with Mohr-Coulomb failure criterion, provided in the ABAQUS program, was used. This material law was extended in the elastic range by a stress-dependency of the oedometric stiffness modulus with the following equation:

$$E_s = \kappa \sigma_{at} \left(\frac{\sigma_m}{\sigma_{at}} \right)^\lambda \quad (1)$$

Herein $\sigma_{at} = 100 \text{ kN/m}^2$ is a reference (atmospheric) stress and σ_m is the current mean principal stress in the considered soil element. The parameter κ determines the soil stiffness at the reference stress state and the parameter λ rules the stress dependency of the soil stiffness.

The material parameters used in the calculations are given in Table 1. Concerning more details about the numerical modelling reference is made to Abdel-Rahman & Achmus (2005).

The finite element calculation is executed stepwise. At first, for the generation of the initial stress state the whole model area is discretized using soil elements only. Subsequently, the monopile is generated by replacing the soil elements located at the pile position by steel elements and activating the contact conditions between pile and soil. Then the vertical load is applied, and finally the horizontal load is applied and increased incrementally.

For a resultant horizontal load of 8 MN and a bending moment at sea-bed level of 240 MNm, which is in the order of a possible design load for the considered large water depths, the horizontal (bedding) stresses acting on the pile in the symmetry plane are shown in Figure 2. A monopile with an embedded length of 30 m in dense sand is considered. The characteristic loading behavior of the pile with bedding stresses of opposite sign above and below a point of rotation can be seen clearly. For the considered case the point of rotation lies about 22 m below sea bed.

In Figure 3, load-displacement curves are given for the same pile dimensions and soil conditions. As a characteristic value, the horizontal displacement at the sea bed level w is plotted versus the horizontal load H . For comparison, also the results gained with the method given in API (2000) are shown. Usually offshore foundation structures are designed with respect to the API regulations. Here the p-y method, which is a special subgrade reaction method, is recommended for the design of laterally loaded piles and p-y curves for different soil conditions are given. From Figure 3 it is evident, that the stiffness of large-diameter monopiles with respect to horizontal loading in sand is overestimated by API-method.

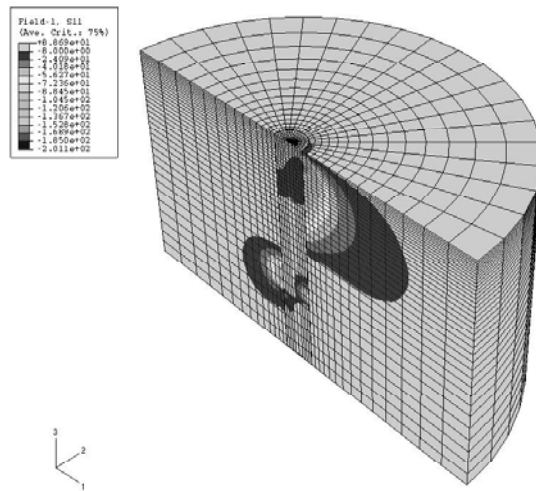

Fig.2: Finite element mesh and horizontal bedding pressure (in the plane of symmetry) for $D = 7.5$ m, $L = 30$ m, dense sand, $H = 8$ MN, $h/L = 1$.

Table1: Material parameters used for dense sand and medium dense sand.

parameter	dense	medium dense
Unit buoyant weight γ'	11 kN/m ³	11 kN/m ³
Oedometric stiffness parameter κ	600	400
Oedometric stiffness parameter λ	0.55	0.60
Poisson's ratio ν	0.25	0.25
Internal friction angle ϕ'	37.5°	35°
Dilation angle ψ	7.5°	5°
Cohesion c	0.1 kN/m ²	0.1 kN/m ²

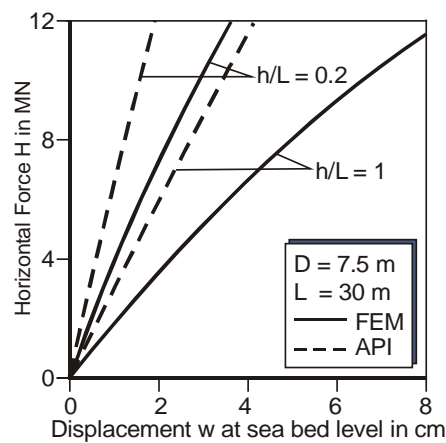

Fig.3: Load-displacement curves for $D = 7.5$ m, $L = 30$ m in dense sand.

3 EFFECT OF CYCLIC LOADING

During the lifetime of an OWEF billions of loading cases induced by wave and wind actions apply to the structure. Thus, the loading has to be classified as intensely cyclic and therefore the fatigue design is of great importance. Concerning the foundation structure, cyclic loading leads to an accumulation of permanent displacements. According to the German offshore regulation (GL 1999), the effect of cyclic loading on the foundation structure has to be taken into account. But, concerning monopiles of large diameter no approved method exists to estimate the permanent displacements due to cyclic loading.

In the API regulations (API 2000) mentioned above cyclic loading is taken into account by a decrease of soil spring stiffness up to a certain depth below the seabed. For large-diameter monopiles, this leads to a moderate increase of the calculated displacements (up to about 20%, dependent on the load). However, the API approach was derived by means of loading tests in which mostly less than 100 load cycles were applied. In fact, strain accumulation does not stop by reaching 100 cycles. Hettler (1981) proposed the following equation for the displacement of a pile in sand loaded by N cycles under the same horizontal load:

$$w_N = w_1 (1 + C_N \ln N) \quad (2)$$

Herein w_1 is the lateral pile head displacement for static loading and C_N is a factor which lies in the range of 0.20 for sand.

Long & Vanneste (1994) proposed a subgrade reaction method with linear increasing subgrade modulus with depth, in which the spring stiffness decrease with the number of load cycles due to the following equation (see Fig. 4 left):

$$k_s(z) = N^{-t} n_{h,1} z \quad (3)$$

Herein t is a factor dependent on the pile installation method, the load characteristic (one- or two-way loading) and on the relative density of the sand. For a driven pile with one-way loading in medium dense sand $t = 0.17$ is recommended. With this value an example was calculated. The results are given in Figure 4. It was found that after 5000 cycles the displacement at the pile top is more than 3 times the static displacement.

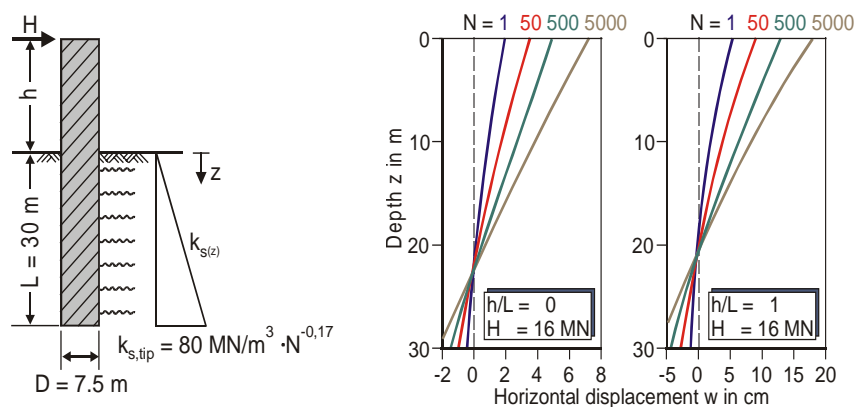

Fig.4: Influence of cyclic one-way loading due to the method from Long & Vanneste (1994) for a monopile $D = 7.5$ m, $L = 30$ m in medium dense sand.

However, this method is not approved yet, and in particular not for large-diameter piles under high bending moments. A new method of analysis is needed, in which the development of displacements for general boundary conditions can be calculated, based on the results of soil laboratory tests. A German standard concerning soil investigations for offshore wind energy converters (BSH 2003) suggests cyclic laboratory tests for the assessment of the behavior under cyclic loads. This new method is outlined in the following section.

4 STIFFNESS DEGRADATION MODEL FOR THE SIMULATION OF DISPLACEMENT ACCUMULATION

In the following, a practical method for the simulation of displacement accumulation is presented. The method is based on finite element calculations, in which the stiffness of the elements are adopted with respect to the number of cycles, to the stress state and to material parameters determined in cyclic triaxial tests.

4.1 Stiffness degradation in cyclic triaxial tests

A principle sketch of the results of a stress-controlled cyclic triaxial test under drained conditions is shown in Figure 5. The plastic portion of the axial strain ε_p^a increases with the number of load cycles. The quantity of the increase is mainly dependent on the initial stress state (confining stress) and on the magnitude of the cyclic load portion.

The increase of the strain can be interpreted as a decrease of the secant stiffness modulus. When the elastic strain is negligible, the degradation of the secant modulus E_{sN} can be formulated in the following way dependent on the plastic strain in the first cycle $\varepsilon_{p,N=1}^a$ and in the N^{th} cycle $\varepsilon_{p,N}^a$:

$$\frac{E_{sN}}{E_{s1}} \cong \frac{\varepsilon_{p,N=1}^a}{\varepsilon_{p,N}^a} \quad (4)$$

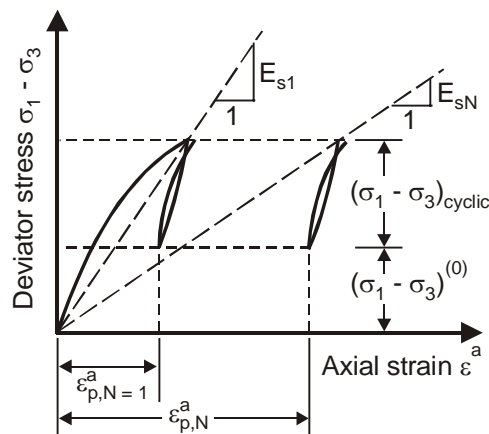

Fig.5: Degradation of secant modulus under cyclic loading in a drained triaxial test.

Equations describing the development of plastic strains in the cyclic triaxial tests were proposed, for instance, from Huurman (1996), Gotschol (2002) and Werkmeister

(2004). Due to the approach of Hoorman used here the increase of deformation or the decrease of stiffness, respectively, can be described by the following equation:

$$\frac{E_{sN}}{E_{s1}} = \frac{\varepsilon_{p,N=1}^a}{\varepsilon_{p,N}^a} = N^{-b_1(X)^{b_2}} \quad (5)$$

Herein N is the number of cycles, X is a stress-dependent variable (cyclic stress ratio), and b_1, b_2 are regression parameters to be determined in triaxial tests.

The cyclic stress ratio is defined as

$$X = \frac{\sigma_{1,cyclic}}{\sigma_{1,f}} \quad (6)$$

wherein $\sigma_{1,f}$ is the main principal stress at failure in a monotonic test. Thus, the stress ratio is dependent on the initial stress state (confining stress) and on the cyclic load level.

4.2 Application of the stiffness degradation model for the pile-soil system

The procedure for the consideration of the stiffness reduction for the pile-soil system is elucidated in Figure 6. In a first step, the loading of the system by the weight of the tower structure and the soil is analysed. With that, the initial stress state for each element of the system is gained.

In the second step the system behavior under horizontal load is analyzed, using the stress-dependent soil stiffness valid for monotonic loading. Thus, the first and the second step are identical to the calculation of the behavior of the pile under monotonic loading.

In the third calculation step, the horizontal load is applied again, but the stiffness of the soil elements are adopted dependent on their stress history with respect to equation (5). With that, for any number of loading cycles N the system behavior can be calculated by a re-calculation of the third step using the appropriate stiffness values.

A problem in the application of the stiffness degradation model for the pile-soil system is the reasonable definition of the initial stress state and the cyclic load level for each element of the discretized system. On one hand, the initial stress state is not isotropic, and on the other hand the principal stress orientation changes during loading and the minor principal stress does not in general remain constant.

To overcome these problems, the following scheme was chosen to derive a characteristic cyclic stress ratio: For the initial stress state (Index ⁽⁰⁾) as well as for the state under action of the cyclic load (Index ⁽¹⁾) a stress ratio X_a is calculated:

$$X_a^{(0)} = \frac{\sigma_1^{(0)}}{\sigma_{1,f}^{(0)}}, \quad X_a^{(1)} = \frac{\sigma_1^{(1)}}{\sigma_{1,f}^{(1)}} \quad (7)$$

The cyclic stress ratio X is then calculated by

$$X = \frac{(X_a^{(1)} - X_a^{(0)})}{1 - X_a^{(0)}} \quad (8)$$

This parameter X characterizes the increase of the stress level in each element under cyclic load and can thus be used for the determination of the stiffness decrease with equation (5). Values $X < 0$, which may arise due to a decrease of deviatoric stress from the initial to the loaded state are not taken into account, i.e. in such cases the soil stiffness remains unchanged.

The degradation parameters b_1 and b_2 in Equation (5) have to be determined from a series of cyclic triaxial tests. If different soil layers exist, this can be easily accounted by different sets of the parameters b_1 and b_2 .

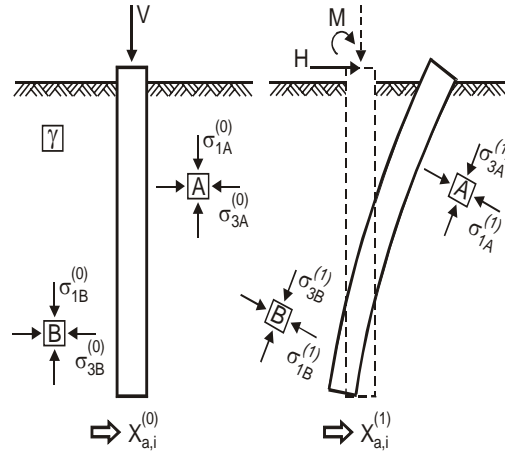

Fig.6: Initial stress state and stress state under cyclic load for the pile-soil system.

4.3 Simulation results

Figure 7 shows the results obtained with the stiffness degradation model. Again a monopile with a diameter of 7.5 m and an embedded length of 30 m in dense sand and medium dense sand was considered.

The regression parameters b_1 and b_2 were determined basing on several triaxial tests with sand samples reported in the literature (Morgan 1966, Timmerman & Wu 1969, Gaskin et al. 1979, Addo-Abedi 1980, Thiel 1988, Huurman 1996, Gotschol 2002 and Wichtmann 2005).

From that, possible parameter combinations were found to be:

- Dense sand: $b_1 = 0.20$, $b_2 = 5.76$;
- Medium dense sand: $b_1 = 0.16$, $b_2 = 0.38$.

A significant increase of the head as well as the toe displacement with cyclic loading of the monopile is found. With increasing displacements, also a slight downward movement of the rotation point (zero deflection point) of the pile occurs.

In Figure 8 the relative increase w_N/w_1 is given for the four systems considered and compared with the approach of Hettler given in Equation (2). Tendencially the Hettler approach is confirmed. However, the model results show that the rate of deformation increase is not constant, but depends on the system. For medium dense sand the rate is higher than for dense sand and for $h/L = 1$ it is higher than for $h/L = 0$. Thus it seems that the rate of accumulation is dependent on the relative load level, i.e. the ratio of the actual to the ultimate load of the system.

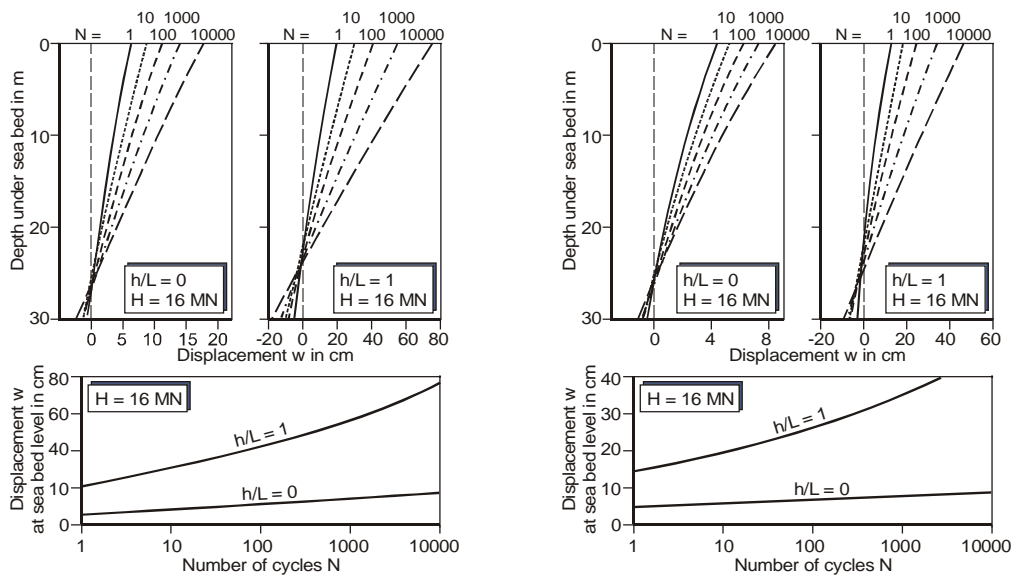

Fig.7: Results for displacement accumulation of a pile in medium-dense sand (left), in dense sand (right).

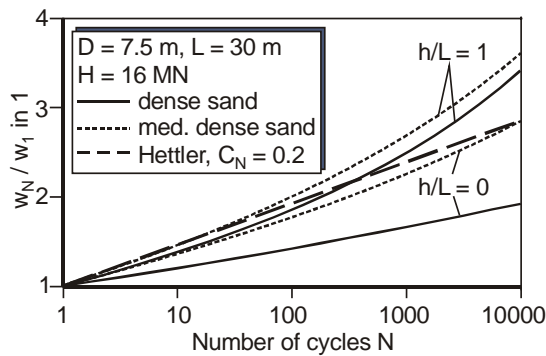

Fig.8: Results for the relative increase of the lateral pile displacement at sea bed level.

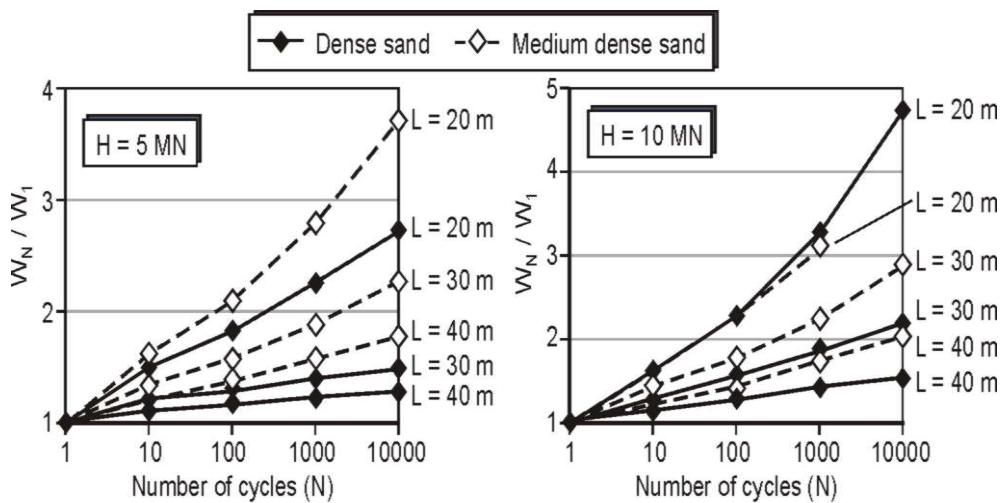

Fig.9: Relative increase of lateral pile displacements for piles with varying embedded lengths ($D=7.50\text{m}$, $h=20.0\text{m}$).

Finally, in Fig. 9 the results of numerical calculations for monopiles with a diameter $D=7.50$ m and a moment arm $h=20.0$ m with varying embedded lengths are given. For comparison reasons the calculations were done for dense and medium dense sand. It can be seen that the piles with longer embedded lengths have a smaller accumulated rate of lateral displacement. This means that increasing the embedded length of the monopile is an efficient way to resist large accumulated displacement under cyclic loading.

5 CONCLUSIONS

For design purposes the accumulation of displacements of monopiles under cyclic loading needs to be taken into account. The proposed method is based on numerical simulations in combination with an evaluation of cyclic triaxial tests. It is in principle also applicable for cohesive soil or layered subsoil and has thus the potential to carry out a site-specific design. Although the numerical results of course need further verification, the first results gained are promising. The model can at least be used to carry out parametric studies to identify important parameters affecting the system behaviour under cyclic loading.

A remaining question is the number of cycles of the design load to be considered in the design. In reality, the amplitude and the direction of the load is varying with the wave heights and the wind velocities, and the maximum load is to be expected only once during the lifetime of the structure. For loads of varying amplitudes Lin & Liao (1999) proposed a strain superposition method to determine the substitute number of design load cycles characterizing the effect of the whole load history. For that, the number of cycles and the static pile displacement at sea bed level for each load amplitude has to be determined, which can be done with the numerical model presented. However, the effect of the varying load directions on the monopile behaviour is an open question, which will be object of further research.

6 ACKNOWLEDGEMENTS

The results presented in this paper were obtained in the framework of the FORWIND research group funded by the Government of the federal state of Lower Saxony, Germany. The support is gratefully acknowledged. Also the numerical calculation were done on the parallel computer system (HLRN) funded by the states of Northern Germany and the state of Berlin.

7 REFERENCES

- [1] Abaqus 2006. User's Manual. Version 6.6.
- [2] Abdel-Rahman, K. & Achmus, M. 2005. *Finite Element Modelling of horizontally loaded Monopile Foundations for Offshore Wind Energy Converters in Germany*. International Symposium on Frontiers in Offshore Geotechnics (ISFOG), Perth, Australia, Sept. 2005.
- [3] Addo-Abedi, F. Y. 1980. *The Behavior of Soils in Repeated Triaxial Compression*. PhD. thesis, Department of Civil Engineering, Queen's University, Kingston, Ontario, Canada.

- [4] API 2000. American Petroleum Institute. *Recommended Practice for Planning, Designing and Constructing Fixed Offshore Platforms- Working Stress Design*, API Recommended Practice 2A-WSD (RP2A-WSD), 21st edition, Dallas.
- [5] BSH 2003. Bundesamt für Seeschifffahrt und Hydrographie. *Standard Baugrunderkundung -Mindestanforderungen für Gründungen von Offshore-Windenergieanlagen*. Germany.
- [6] DNV 2004. Det Norske Veritas. *Design of Offshore Wind Turbine Structures*. Offshore Standard, Norway.
- [7] Gaskin, P. N., Raymond, R. P., Addo-Abedi, F. Y. & Lau, J. S. 1979. *Repeated compressive loading of a sand*. Canadian Geotechnical Journal, 16(4), 798-802.
- [8] GL 1999. Germanischer Lloyd. *Rules and Regulations, Offshore Wind Energy Converters*. Hamburg, Germany.
- [9] Gotschol, A. 2002. *Veränderlich elastisches und plastisches Verhalten nichtbindiger Böden und Schotter unter zyklisch-dynamischer Beanspruchung*. Schriftenreihe Geotechnik der Universität Kassel, Heft 12.
- [10] Hettler, A. 1981. *Verschiebungen starrer und elastischer Gründungskörper in Sand bei monotoner und zyklischer Belastung*. Veröffentlichungen des Instituts für Bodenmechanik und Felsmechanik der Universität Fridericiana in Karlsruhe, Heft 90.
- [11] Huurman, M. 1996. *Development of traffic induced permanent strains in concrete block pavements*. Heron, Vol.41, No.1. pp. 29-52.
- [12] Lin, S.-S. & Liao, J.-C. 1999. *Permanent strains of piles in sand due to cyclic lateral loads*. ASCE Journal of Geotechnical and Geoenvironmental Engineering, Vol.125, No.9, pp. 798-802.
- [13] Long, J. H. & Vanneste, G. 1994. *Effects of cyclic lateral loads on piles in sand*. ASCE Journal of Geotechnical Engineering, Vol. 120, No. 1. pp.225-243.
- [14] Morgan, J. R. 1966. *The response of Granular Materials to Repeated Loading*. Proceeding 3rd Australian Road Board Conference, Sydney, 1178-1192.
- [15] Thiel G. 1988. *Steifigkeit und Dämpfung von wassergesättigtem Feinsand unter Erdbebenbelastung*. Schriftenreihe des Lehrstuhls für Grundbau und Bodenmechanik der Ruhr-Universität Bochum, Heft 14.
- [16] Timmerman, D. H. & Wu, T. H. 1969. *Behavior of dry sands under cyclic loading*. ASCE Journal of the Soil Mechanics and Foundations Division, 117(3), 429-466.
- [17] Werkmeister, S. 2004. *Permanent Deformation Behaviour of Unbound Granular Materials in Pavement Constructions*. Schriftenreihe der Professur Straßenbau der TU Dresden, Heft 12.
- [18] Wichtmann, T. 2005. *Explicit accumulation model for non-cohesive soils under cyclic loading*. Schriftenreihe des Lehrstuhls für Grundbau und Bodenmechanik der Ruhr-Universität Bochum, Heft 38.